

187 Vonkprop Road
Samcor Park
Pretoria
0184
South Africa
P.O. Box 782, Silverton, 0127
Reg. No.: 1996/000393/23



Design, Manufacture and Supply of Earth Boring Machines and Equipment Ontwerp en Vervaardiging van Grond-boormasjiene en Toerusting

TECHNICAL SHEET: SR100-3 DRILL RIG

The **SR100-3** water-well/ reverse circulation drill rig is a robust, simple reliable and capable machine. This drill rig has no electronic systems that control any functions, thus eliminating untimely and unforeseen standing time due to dust ingression, thereby increasing machine availability, reliability and then of course production.

The derrick is fabricated from hollow drawn steel tube and hot-rolled sections. The feed cylinder has a 3.4 meter stroke and is coupled to an inner derrick, which carries the rotary head.

The rotary head is our SRD Gearbox type which was designed by Super Rock Drills and is manufactured in-house. Extra heavy-duty bearings, take all forces produced during drilling operations. The bull shaft on the air swivel has a 4.5" remet / 102 ARD or a 3.5" API thread to which the drill string is attached. A built-in shock absorber on the head minimizes vibration and shock loads to the machine and drill string. A hydraulic two-speed system is fitted as a standard to all machines. The rotary head is fitted to a carrier which runs on the outer sides of the derrick on four heavy duty blocks which almost eliminates all wear. Apart from reverse circulation drilling the rotary head can do open hole DTH hammer, mud rotary, air rotary, auger, tricone and RAB drilling.

Four hydraulic outriggers are fitted to the outer corners of the rig for easy and accurate levelling of the rig.

A single hydraulic cylinder is used to raise and lower the derrick. All hydraulic controls are fitted into a single panel in front of the operator, making the operation of the machine very easy and simple even for unskilled operators. A fingertip down feed valve is fitted to ensure even pressures during drilling operations.

The working table consists of removable half-moons combined with replaceable guide collars, which when removed, easily allows 305mm diameter tools to pass through. Guide bushes are supplied to suit the drill string.

The drill rig's power pack consists of a four-cylinder Kirloskar engine close coupled to our tried and tested hydraulic system. All necessary air, fuel and oil filters are included.



Tel: +27 12 803 7925/6/7/8
Fax: +27 12 803 7085
E-mail: suprock@mweb.co.za
Sales E-mail: sales@superrockdrills.co.za
Website: www.superrockdrills.com
Export Customs Code: 00653225

Members: GGM JOOSTE (MANAGING), EVA KIRSTEIN



A 10-litre inline oil lubrication for DTH hammer drilling is fitted as a standard.

The **SR100-3** is a very simple and easy machine to operate and maintain. Being locally designed and manufactured with over four hundred machines running in the mining, exploration, water well and piling industries proves that the **SR100-3** range is a very popular and robust choice amongst drilling contractors.



Tel: +27 12 803 7925/6/7/8
Fax: +27 12 803 7085
E-mail: suprock@mweb.co.za
Sales E-mail: sales@superrockdrills.co.za
Website: www.superrockdrills.com
Export Customs Code: 00653225

Members: GGM JOOSTE (MANAGING), EVA KIRSTEIN



MAST	ROTARY HEAD
<p>Fabricated from hollow drawn steel tube and hot-rolled sections. Telescopic design, direct cylinders couples the inner derrick to the outer derrick. No cables or chains are required.</p> <p>Mast Raising Cylinders - 1 Mast Locking Options - For vertical drilling - Dump mast for angle drilling</p>	<p>Options</p> <ul style="list-style-type: none"> - SRD Gearbox (Reduction type) 0-100 RPM Spindle hole 80mm Max torque options 4000-12000nm Spindle thread options: <ol style="list-style-type: none"> 1. 102 ARD 2. 4 ½" Remet 3. 3 ½" Regular API
DRILLING PARAMETERS	FEED SYSTEM
<p>Hole Diameter - 3" - 18" Depth Calculation(1) - Maximum depth using 25kg/m drill string will be 288m @ 20% safety margin Depth Calculation(2) - Maximum depth using 25kg/m drill string will be 200m @ 43% safety margin Single Pass - 3m</p>	<p>Type - 2 x Telescopic direct cylinder Pull Back - 9 Ton Down Force - 3.4 Ton Stroke - 3400mm / 3.4m</p>
RECOMMENDED COMPRESSOR CAPACITY	DECK ENGINE
<p>Flow Rate - 1200 CFM Pressure - 23 Bar</p>	<p>Make - Kirloskar Engine Type - HA494 Rating kW/HP - 48/66 RPM - 1800</p>
HYDRAULIC SYSTEM	DUST SUPPRESSION
<p>Oil Type - Hydraulic 68 Rig Pumps - Gear Pumps @ 200 Bar</p>	<p>Piston pump - 21l/min @ 200 Bar</p>
HAMMER LUBRICATION	GENERAL SPECIFICATIONS
<p>Type - Venturi system - 10 Litres</p>	<p>Lighting - LED Lights Emergency Stops Protection guards on all hot surfaces Lock-out protection</p>

Tel: +27 12 803 7925/6/7/8
Fax: +27 12 803 7085
E-mail: suprock@mweb.co.za
Sales E-mail: sales@superrockdrills.co.za
Website: www.superrockdrills.com
Export Customs Code: 00653225

Members: GGM JOOSTE (MANAGING), EVA KIRSTEIN



SRD GEARBOX CAPABILITIES	COOLING - HYDRAULICS
Types <ul style="list-style-type: none"> - Reverse Circulation (RC) - Open Hole DTH - Waterwells - Mud Rotary - Air Rotary - Auger - RAB Drilling - Air Core 	Oil cooler fitted <ul style="list-style-type: none"> - 12v Electrical driven fan
RIG STABILIZATION	ROD BREAKING SYSTEM
4 X Hydraulic outriggers <ul style="list-style-type: none"> - Boxed - Bore 80mm - Stroke 900mm 	Options <ul style="list-style-type: none"> - Manual keeper key - Hydraulic keeper key - Break-out cylinder & spanner
WINCH (OPTIONAL)	MUD PUMP (OPTIONAL)
Standard <ul style="list-style-type: none"> - Fixed winch - 	Standard <ul style="list-style-type: none"> - 4x3x13 Centrifugal *Hydraulic Drive. Optional <ul style="list-style-type: none"> - Duplex, Triplex, Orbit.
AIR LINE SYSTEM	UNDERCARRIAGE OPTIONS
All 2" steel & 2" rubber hoses rated @ 80 Bar pressure.	<ul style="list-style-type: none"> - 4x2, 6x4, 8x4 trucks - Steel track undercarriage system run by the deck engine (deck engine may change for track-mounted rigs, depending on loads added to the deck.) - Trailer mounted; brake axle (dual axle single tyre) - Self-driven; hydraulic drive (single axle double tyre)

Tel: +27 12 803 7925/6/7/8
Fax: +27 12 803 7085
E-mail: suprock@mweb.co.za
Sales E-mail: sales@superrockdrills.co.za
Website: www.superrockdrills.com
Export Customs Code: 00653225

Members: GGM JOOSTE (MANAGING), EVA KIRSTEIN



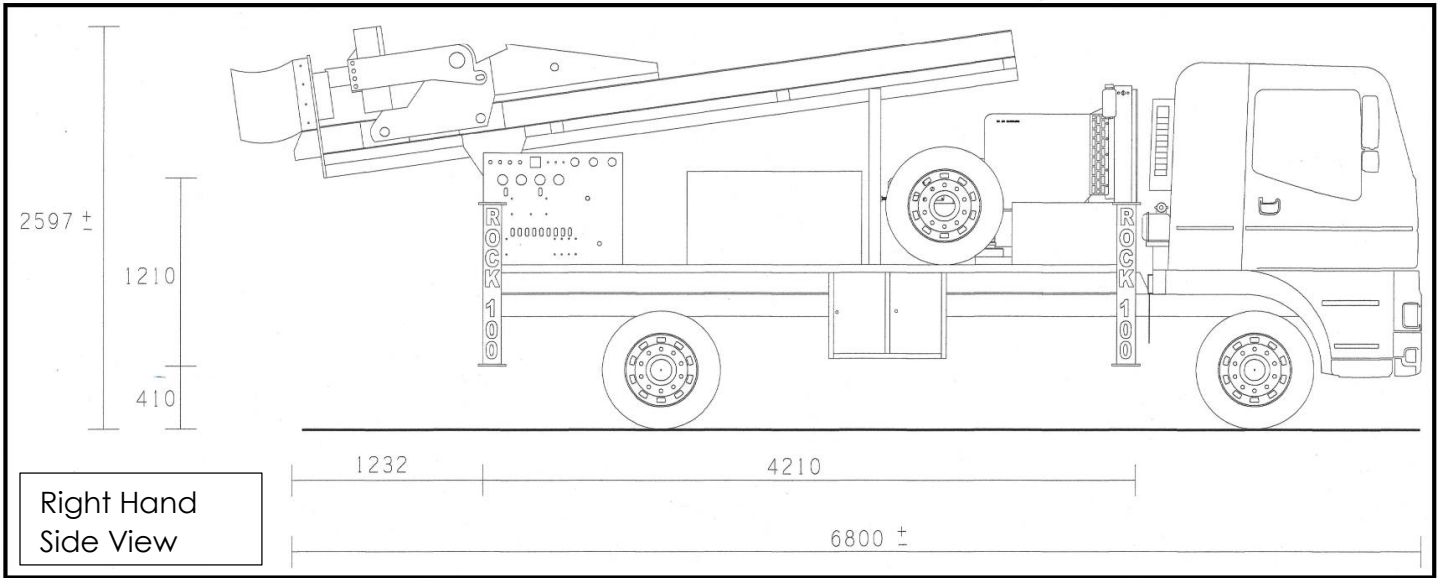

Dimensions may vary slightly according to carrier truck specifications

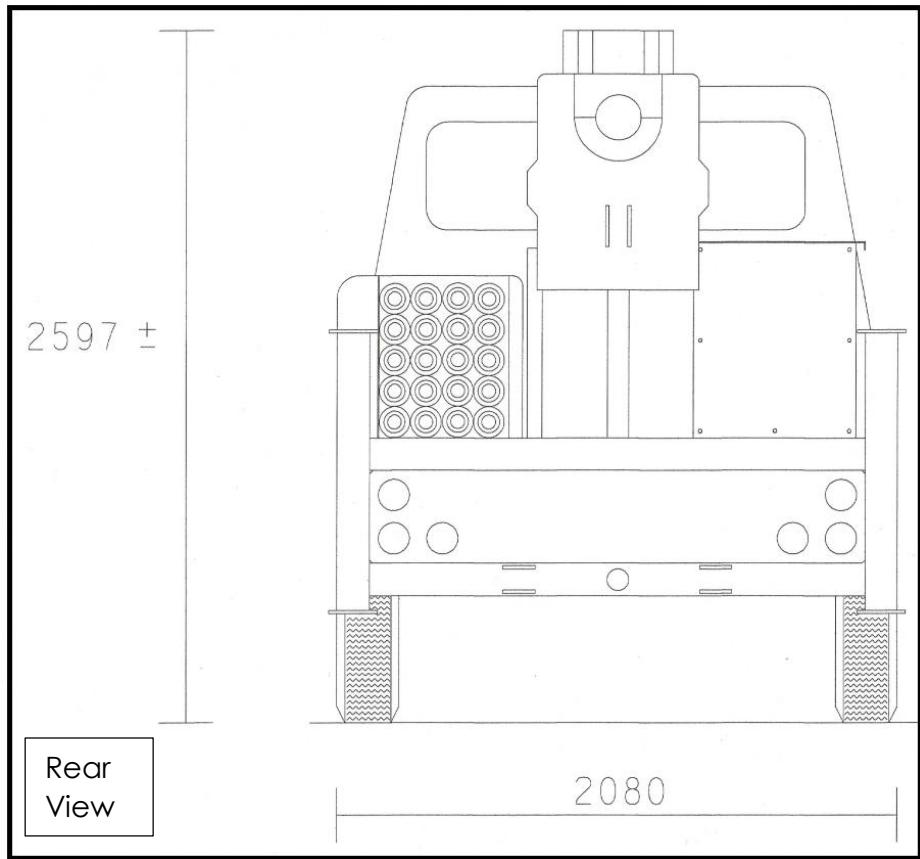

Tel: +27 12 803 7925/6/7/8
 Fax: +27 12 803 7085
 E-mail: suprock@mweb.co.za
 Sales E-mail: sales@superrockdrills.co.za
 Website: www.superrockdrills.com
 Export Customs Code: 00653225

Members: GGM JOOSTE (MANAGING), EVA KIRSTEIN



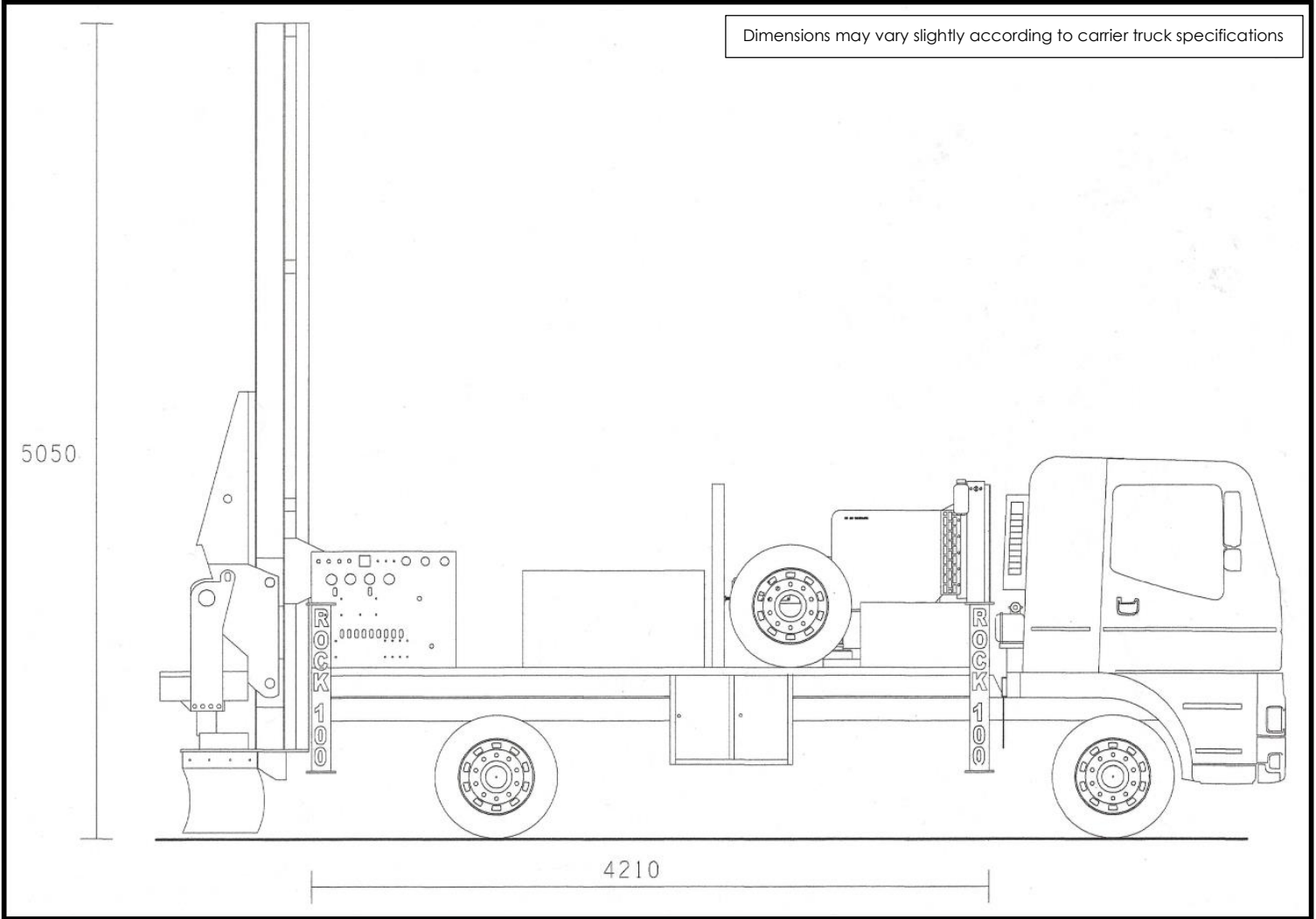

Right Hand Side View –
Mast Vertical

Tel: +27 12 803 7925/6/7/8
Fax: +27 12 803 7085
E-mail: superrock@mweb.co.za
Sales E-mail: sales@superrockdrills.co.za
Website: www.superrockdrills.com
Export Customs Code: 00653225

Members: GGM JOOSTE (MANAGING), EVA KIRSTEIN



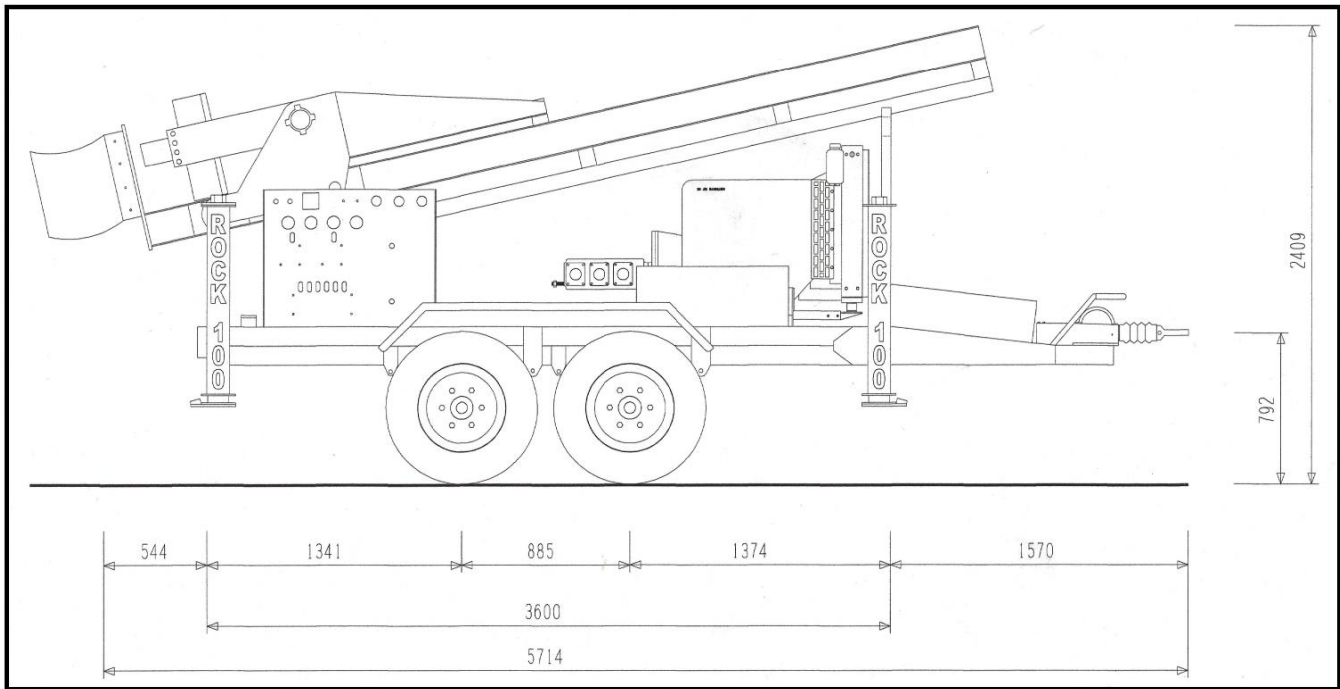

Right Hand
Side View

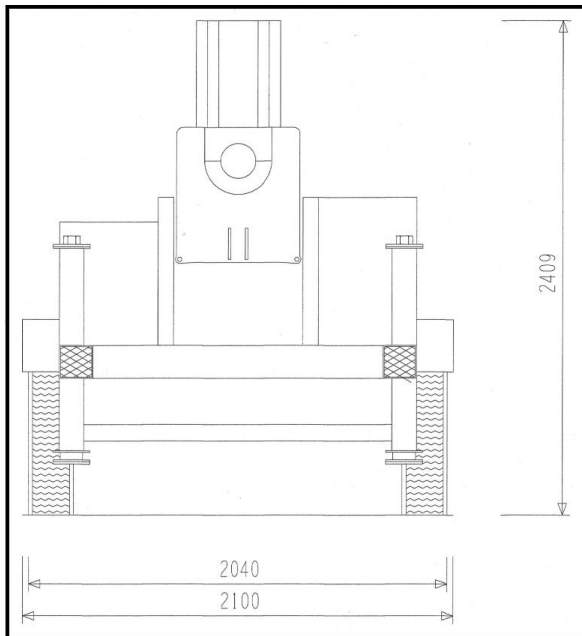

Rear
View

Dimensions may vary slightly according to carrier truck specifications.
Dimensions in millimetres.

Tel: +27 12 803 7925/6/7/8
 Fax: +27 12 803 7085
 E-mail: superrock@mweb.co.za
 Sales E-mail: sales@superrockdrills.co.za
 Website: www.superrockdrills.com
 Export Customs Code: 00653225

Members: GGM JOOSTE (MANAGING), EVA KIRSTEIN

